

## Jazzorchester Tirol

### Front of house:

Analog console\*: 32 ch, 4 aux-sends pre, 2 aux-sends post  
Midas, Yamaha, Soundcraft

Digital console : Yamaha M7CL, PM5D, Digico D1 live, D5 live

EQ\*: 6 ch, Klark DN 360, DN 370, BSS FCS 960

FX\*: 1 x Lexicon PCM, v T.C. 2000/3000/5000, v Yamaha SPX

Dynamics\*: 6 ch, DBX 160/166, BSS 402/404

Misc.: talkback-mic

PA: d&b, Meyer, Nexo, Turbosound  
matching room-size and number of audience

Monitoring: 8 floorwedges of identical brand, 4 mixes from foh

Backline: grand piano, 440 Hz, piano tuner  
bass head SWR, Ampeg, Gallien Krueger, Markbass  
bass cabinet 4 x 10" SWR, Ampeg, Gallien Krueger, Markbass

Misc: stage-size with grand piano 10 x 06 m  
stage-size with keyboard instead of grand piano 08 x 06 m  
riser 3 x 2 x 0,20/0,40 m for 4 trombones seated and  
4 trumpets standing  
9 chairs without armrests for 5 saxophones and 4 trombones  
16 musicstands

Lights: wash, n.c.  
sufficient lighting for musicstands

# Jazzorchester Tirol

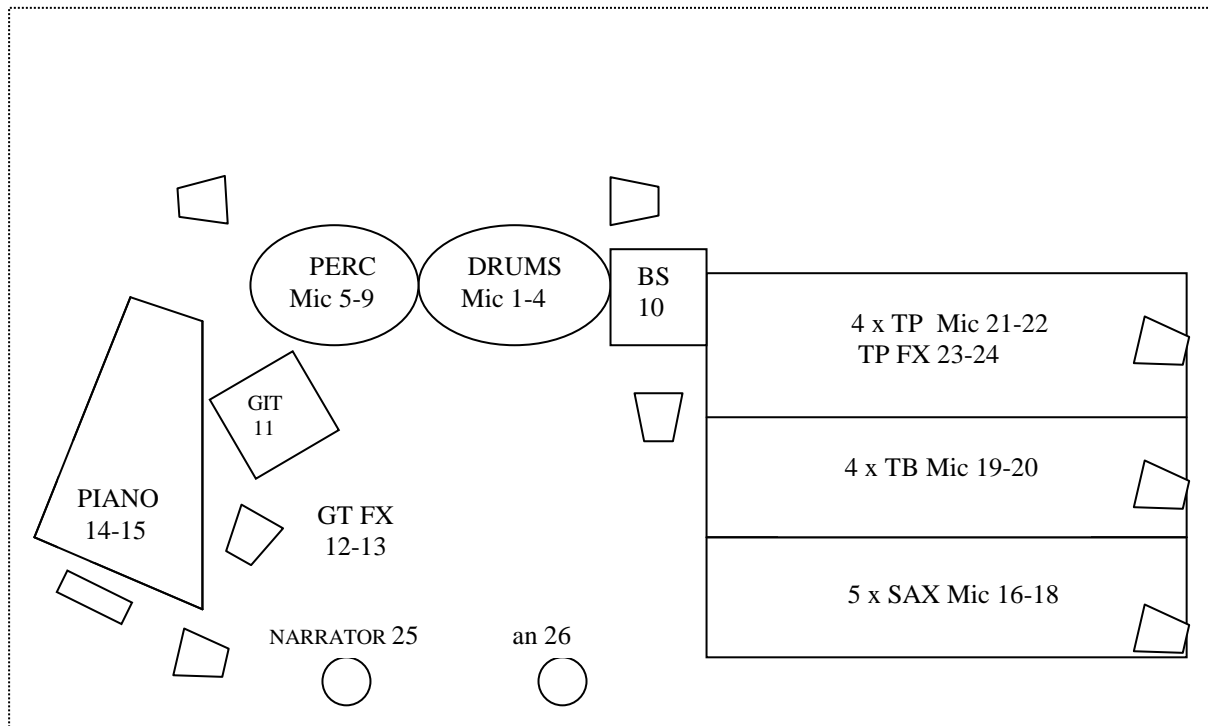

artist: jazzorchester tirol			venue:		
ch	instrument	mic	ch	instrument	mic
1	bassdrum	beta 52	14	piano diskant	414, 184
2	snare	beta 57	15	piano bass	414, 184
3	oh	414, 184	16	sax	pl 20, 421
4	oh	414, 184	17	sax	pl 20, 421
5	conga	sm 57	18	sax	pl 20, 421
6	conga	sm 57	19	trombone	pl 20, 421
7	perc oh	414, 184	20	trombone	pl 20, 421
8	perc oh	414, 184	21	trumpet	pl 20, 421
9	toys	414, 184	22	trumpet	pl 20, 421
10	bass	bss di	23	trumpet fx	bss di
11	git	sm 57	24	trumpet fx	bss di
12	git fx	bss di	25	narrator	headset
13	git fx	bss di	26	anouncement	sm 58
	mon mix 1	piano			
	mon mix 2	git		tech-contact:	
	mon mix 3	perc, dr, bs		<a href="mailto:buratti@clearsound.at">buratti@clearsound.at</a>	
	mon mix 4	horns		<a href="http://www.clearsound.at">www.clearsound.at</a>	